

ON SNAKE CONES, ALTERNATING CONES AND RELATED CONSTRUCTIONS

KATSUYA EDA, UMED H. KARIMOV, DUŠAN REPOVŠ AND ANDREAS
ZASTROW

Waseda University, Japan, Academy of Sciences of Tajikistan, Tajikistan,
University of Ljubljana, Slovenia and Gdansk University, Poland

ABSTRACT. We show that the Snake on a square $SC(S^1)$ is homotopy equivalent to the space $AC(S^1)$ which was investigated in the previous work by Eda, Karimov and Repovš. We also introduce related constructions $CSC(-)$ and $CAC(-)$ and investigate homotopical differences between these four constructions. Finally, we explicitly describe the second homology group of the Hawaiian tori wedge.

1. INTRODUCTION

The functor $SC(-, -)$, mapping from the category of all spaces with base points and continuous mappings to the subcategory of simply connected spaces was constructed in [3]. We named $SC(X, x)$ the *Snake cone* over a pointed space (X, x) . In the case when the space X is a circle S^1 with a base point x , the resulting space $SC(S^1, x)$, called the *Snake on a square*, is a cell-like simply connected 2-dimensional Peano continuum ([3]). It was shown in [4] that the space $SC(S^1, x)$ is not only noncontractible but is also nonaspherical (because the second homotopy group of this space is nontrivial, see also [5, 6]). We investigated another functor $AC(-, -)$ in [7], which shares many properties with $SC(-, -)$, and we proved that $AC(\mathbb{H}, o)$ is not homotopy equivalent to $SC(\mathbb{H}, o)$ for the Hawaiian earring \mathbb{H} with the distinguished point o . We named $AC(X, x)$ the *Alternating cone* over a pointed space (X, x) . In the present paper we shall introduce some variants of these constructions, i.e., the *Collapsed snake cone* $CSC(X, x)$ and the

2010 *Mathematics Subject Classification.* 54F15, 55N10, 54G20, 55Q52.

Key words and phrases. Noncontractible compactum, weak homotopy equivalence, trivial shape, Peano continuum, topologist sine curve, snake on a square, collapsed snake cone, collapsed alternating cone, asphericity, Hawaiian earring, Hawaiian tori.

Collapsed alternating cone $CAC(X, x)$, and we shall investigate homotopy equivalences among these four functors.

Our main results are the following:

THEOREM 1.1. *If a space X is semi-locally strongly contractible at $x_0 \in X$, then $SC(X, x_0)$ and $CSC(X, x_0)$ (resp. $AC(X, x_0)$ and $CAC(X, x_0)$) are also homotopy equivalent.*

THEOREM 1.2. *The Snake on a square $SC(S^1, x_0)$ and the Alternating cone $AC(S^1, x_0)$ are homotopy equivalent for every $x_0 \in S^1$.*

THEOREM 1.3. *For the Hawaiian earring \mathbb{H} with the base point o the following properties hold:*

- (1) $SC(\mathbb{H}, o)$ and $AC(\mathbb{H}, o)$ (resp. $SC(\mathbb{H}, o)$ and $CSC(\mathbb{H}, o)$) are not homotopy equivalent;
- (2) $AC(\mathbb{H}, o)$ and $CAC(\mathbb{H}, o)$ are not homotopy equivalent; but
- (3) $CSC(\mathbb{H}, o)$ and $CAC(\mathbb{H}, o)$ are homotopy equivalent.

THEOREM 1.4. *For the 2-dimensional torus T with the base point $z_0 \in T$, the spaces $SC(T, z_0)$ and $AC(T, z_0)$ are not homotopy equivalent and consequently, also the spaces $CSC(T, z_0)$ and $CAC(T, z_0)$ are not homotopy equivalent.*

Consequently, we get the following:

COROLLARY 1.5. *For each pair of functors $SC(-, -)$, $AC(-, -)$, $CSC(-, -)$ and $CAC(-, -)$, there exists a space such that the resulting functorial spaces are not homotopy equivalent.*

We shall define the *Hawaiian tori wedge* similarly to the Hawaiian earring by replacing the circle by the torus. A precise definition and supporting notions will be given in the forthcoming sections.

THEOREM 1.6. *Let \mathbb{H}_T be the Hawaiian tori wedge. Then the following properties hold:*

- (1) $\pi_1(\mathbb{H}_T)$ is isomorphic to the free σ -product of countable copies of the free abelian group of rank two;
- (2) $\pi_2(\mathbb{H}_T)$ is trivial; and
- (3) $H_2(\mathbb{H}_T)$ is isomorphic to the free abelian group on countably many generators. The generators are associated with the fundamental cycles of the tori.

This contrasts with the known results concerning the 2-dimensional Hawaiian earring \mathbb{H}_2 . Namely,

- (1) $\pi_1(\mathbb{H}_2)$ is trivial ([2, Theorem A.1]); and
- (2) $\pi_2(\mathbb{H}_2) \cong H_2(\mathbb{H}_2)$ is isomorphic to the direct product of countably many copies of \mathbb{Z} ([8, Corollary 1.2]).

Throughout this paper X stands for a path-connected compact Hausdorff space. Standard notions are undefined and we refer the reader to [11].

2. THE CONSTRUCTION OF THE SNAKE CONE $SC(X, x)$, THE ALTERNATING CONE $AC(X, x)$ AND THEIR VARIATIONS

In this paper we shall apply our constructions only to compact spaces, and so the definitions of topologies, which we shall use, may look to be different from the original ones in [3], but they are in fact the same. The construction of the Snake cone is based on the piecewise-linear Topologist sine curve \mathcal{T} which is homeomorphic to the usual Topologist sine curve. To describe this space and for the next discussion we need to fix some terminology. For any two points A and B in the plane \mathbb{R}^2 , we denote by $[A, B]$ the linear segment connecting these points. The unit segment of the real line is denoted by \mathbb{I} . The point of the coordinate plane \mathbb{R}^2 with coordinates a and b is denoted as $(a; b)$, particularly when we describe the points in $SC(X, x)$ and $AC(X, x)$. Let $A = (0; 0), B = (0; 1), A_n = (1/n; 0), B_n = (1/n; 1)$ be points and let $L = [A, B], L_{2n-1} = [A_n, B_n], L_{2n} = [B_n, A_{n+1}]$ be the segments in the plane \mathbb{R}^2 for $n \in \mathbb{N} = \{1, 2, 3, \dots\}$. We also let $C_{2n-1} = (1/n; 1/2)$ and $C_{2n} = (1/(n+1) + 1/2n(n+1); 1/2)$ for $n \in \mathbb{N}$ and $C = (0; 1/2)$, see Figure 1.

The piecewise linear Topologist sine curve \mathcal{T} is the subspace of \mathbb{R}^2 defined as the union of L_n and L .

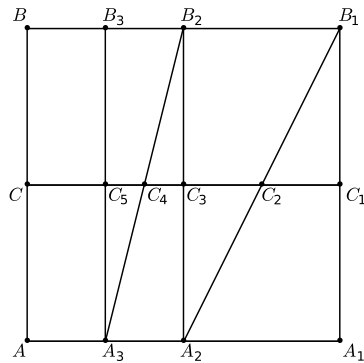

FIGURE 1. Topologist sine curve

The Snake cone $SC(X, x)$ over a compact pointed space (X, x) is the quotient space of the topological sum $(X \times \mathcal{T}) \sqcup \mathbb{I}^2$ via the identification of the points $(x, t) \in X \times \mathcal{T}$ with $t \in \mathcal{T} \setminus L \subset \mathbb{I}^2$ and the identification of each set $X \times \{t\}$ with the point t , for every $t \in L$ ([3]).

Define the following closed subspace of $X \times \mathbb{I}^2$

$$Y = X \times \{0\} \times \mathbb{I} \cup \bigcup_{n \in \mathbb{N}} X \times \{1/n\} \times \mathbb{I} \cup \{x\} \times \mathbb{I} \times \mathbb{I}.$$

The Alternating cone $AC(X, x)$ over a compact pointed space (X, x) is defined as the quotient space of Y via the identification of each set $X \times \{0\} \times \{y\}$ to $(0; y)$, $X \times \{1/(2n - 1)\} \times \{0\}$ to $A_{2n-1} = (1/(2n - 1); 0)$ and $X \times \{1/2n\} \times \{1\}$ to $B_{2n} = (1/2n; 1)$ for each $y \in \mathbb{I}$ and each $n \in \mathbb{N}$, respectively.

In both cases of $SC(X, x)$ and $AC(X, x)$ let $p : SC(X, x) \rightarrow \mathbb{I}^2$ or $p : AC(X, x) \rightarrow \mathbb{I}^2$ be the natural projection and define p_1 and p_2 by $p(u) = (p_1(u); p_2(u))$.

The spaces $CSC(X, x)$ and $CAC(X, x)$ are obtained from spaces $SC(X, x)$ and $AC(X, x)$, respectively by identifying each point $(a; b) \in \mathbb{I}^2$ with $(0; b)$ for all $a, b \in \mathbb{I}$, i.e., by collapsing \mathbb{I}^2 to L . We also denote this distinguished interval by L . The projection p_2 is defined on all the spaces $SC(X, x)$, $AC(X, x)$, $CSC(X, x)$, and $CAC(X, x)$, while p_1 is defined only on $SC(X, x)$ and $AC(X, x)$.

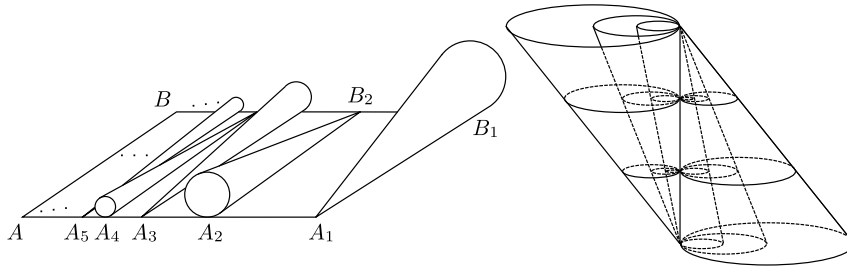

FIGURE 2. $AC(S^1)$ and $CAC(S^1)$

For $m, n \in \mathbb{N}$ with $m \leq n$, define $SC_{m,n}(X, x) = p_1^{-1}([1/n, 1/m])$ and $SC_m(X, x) = p_1^{-1}([0, 1/m])$ when p is mapping from $SC(X, x)$ to \mathbb{I}^2 , and define $AC_{m,n}(X, x) = p_1^{-1}([1/n, 1/m])$ and $AC_m(X, x) = p_1^{-1}([0, 1/m])$ when p is mapping from $AC(X, x)$ to \mathbb{I}^2 .

For a subspace S of these spaces and a map f defined on S whose range is one of these spaces, f is called *flat*, if $p_2(u) = p_2(v)$ implies $p_2(f(u)) = p_2(f(v))$ for $u, v \in S$. Similarly, a homotopy $H : S \times \mathbb{I} \rightarrow Z$ where Z is one of these four spaces, is said to be flat, if the map $H(-, t)$ is flat for each $t \in \mathbb{I}$.

For a subspace S of these spaces and a map f defined on S whose range is one of these spaces, f is called *level-preserving* (resp., ε -*level-preserving*), if $p_2(f(u)) = p_2(u)$ (resp., $|p_2(f(u)) - p_2(u)| < \varepsilon$) for every $u \in S$. Similarly, a homotopy $H : S \times \mathbb{I} \rightarrow Z$ where Z is one of these four spaces, is *level-preserving*

(resp., ε -level-preserving), if $p_2(H(u), t) = p_2(u)$ (resp., $|p_2(H(u, t)) - p_2(u)| < \varepsilon$) for every $u \in S$ and $t \in \mathbb{I}$.

The cone over a space X , denoted by $C(X)$, is defined as the quotient space of $X \times \mathbb{I}$ by identifying $X \times \{1\}$ to a point and so we can describe points on the cone by points on $X \times \mathbb{I}$.

When arguments are not related to base points, we shall abbreviate $SC(X, x)$ by $SC(X)$, and so on.

Finally, we introduce a construction of spaces for our further investigation. For spaces X_n ($n \in \mathbb{N}$) with $x_n \in X_n$, let $\tilde{\bigvee}_{n \in \mathbb{N}}(X_n, x_n)$ be the space obtained by identifying all x_n 's to the point x^* so that every neighborhood of x^* contains almost all X_n 's and each subspace topology of X_n coincides with the topology of X_n . When the index set is finite, we write $\bigvee_{n=1}^k(X_n, x_n)$ as usual. When each X_n is a copy of the circle, $\tilde{\bigvee}_{n \in \mathbb{N}}(X_n, x_n)$ is homeomorphic to the Hawaiian earring. When each X_n is a copy of the 2-dimensional torus T , we call $\tilde{\bigvee}_{n \in \mathbb{N}}(X_n, x_n)$ the Hawaiian tori wedge and denote it by \mathbb{H}_T .

REMARK 2.1. The Sombbrero space was introduced and studied in [1]. The piecewise linear Sombbrero space is defined as the subspace of \mathbb{R}^3 obtained by rotating \mathcal{T} about its limiting interval $L \subseteq \{0\} \times \{0\} \times \mathbb{R}$. The Sliced Sombbrero space is then defined as the union of the Sombbrero space and $\mathbb{I} \times \{0\} \times \mathbb{I}$. In other words, the Sombbrero space is the quotient space of the product $S^1 \times \mathcal{T}$ that results from identifying the circles $S^1 \times \{a\}$ for $a \in L \subset \mathcal{T}$ to one point, and the Sliced Sombbrero space is the quotient space of the topological sum of the Sombbrero space and the unit square \mathbb{I}^2 that results from identifying the two topological sine-curves \mathcal{T} which have been defined in each of the components of this topological sum.

In this form one can see that the Sliced Sombbrero and the Snake on a square $SC(S^1)$ are analogously built and thus are homeomorphic. Our starting point of the investigations in this paper was the discovery of this fact and the homotopy equivalence between the Sliced Sombbrero and $AC(S^1)$, which is reflected in Theorem 1.2.

While describing the proof of Theorem 1.2, we found the constructions $CSC(X, x)$ and $CAC(X, x)$. Though differences among the constructions $SC(X, x)$, $AC(X, x)$, $CSC(X, x)$ and $CAC(X, x)$, except the difference between $CSC(X, x)$ and $CAC(X, x)$, were shown using the Hawaiian earring \mathbb{H} , the difference was left open. Similarly as for the circle S^1 , $SC(S^n)$ and $AC(S^n)$ are homotopy equivalent for the n -sphere S^n , which was meanwhile shown by the first author. We found that $SC(T)$ and $AC(T)$ are not homotopy equivalent for the torus T and by Theorem 1.1 $CSC(T)$ and $CAC(T)$ are not homotopy equivalent, either. Since a space which is homotopy equivalent to the Hawaiian tori wedge, appears in these spaces and it works in the proof, our interests turned to $H_2(\mathbb{H}_T)$. This explains how our results in this paper are related.

3. PROOF OF THEOREMS 1.1 AND 1.2

First we give another presentation of the space $CSC(X, x)$ and the space $CAC(X, x)$. Let X_n be a copy of X and x_n a copy of $x_0 \in X$ for each n . Then $CSC(X, x)$ is homeomorphic to the quotient space of $\widetilde{\bigvee}_{n \in \mathbb{N}}(X_n, x_n) \times \mathbb{I}$, obtained by identifying $X_{2n} \times \{0\}$ with $X_{2n-1} \times \{0\}$, and by identifying $X_{2n+1} \times \{1\}$ with $X_{2n} \times \{1\}$ for $n \in \mathbb{N}$.

To present $CAC(X, x)$ in another way, let $C(\widetilde{\bigvee}_{n \in \mathbb{N}}(X_{2n-1}, x_{2n-1}))$ be the cone over $\widetilde{\bigvee}_{n \in \mathbb{N}}(X_{2n-1}, x_{2n-1})$, where x^* is the point of identification and $C(\widetilde{\bigvee}_{n \in \mathbb{N}}(X_{2n}, x_{2n}))$ with x^{**} analogously. We denote the interval connecting the vertex of the first cone and the base point x^* by $\{x^*\} \times \mathbb{I}$, where $(x^*, 1)$ denotes the vertex and $(x^*, 0)$ denotes the point x^* in the base space $\widetilde{\bigvee}_{n \in \mathbb{N}}(X_{2n-1}, x_{2n-1})$. We denote the corresponding interval by $\{x^{**}\} \times \mathbb{I}$, analogously for the second cone. Then $CAC(X, x_0)$ is homeomorphic to the quotient space of the disjoint union

$$C(\widetilde{\bigvee}_{n \in \mathbb{N}}(X_{2n-1}, x_{2n-1})) \sqcup C(\widetilde{\bigvee}_{n \in \mathbb{N}}(X_{2n}, x_{2n}))$$

via the identification of (x^*, t) with $(x^{**}, 1 - t)$ for $t \in \mathbb{I}$.

A space X is called *semi-locally strongly contractible* at $x_0 \in X$, if there exists a neighborhood U of x and a continuous map $H : U \times \mathbb{I} \rightarrow X$ such that $H(u, 1) = u$, $H(u, 0) = x_0$ and $H(x_0, t) = x_0$, for every $u \in U$ and $t \in \mathbb{I}$.

Proof of Theorem 1.1. By the semi-local strong contractibility at $x_0 \in X$, we have U and H as above. Choose neighborhoods V_0 and V_1 of x_0 and continuous maps $F, G : X \rightarrow \mathbb{I}$ such that $\overline{V_0} \subseteq V_1, \overline{V_1} \subseteq U$, $F(x_0) = 0$ and $F(x) = 1$ for $x \notin V_0$ and $G(x) = 0$ for $x \in \overline{V_0}$ and $G(x) = 1$ for $x \notin V_1$. We denote the quotient map from $SC(X, x_0)$ to $CSC(X, x_0)$ by σ . Observe that the restriction of σ to $p^{-1}(\mathcal{T}) \setminus \mathcal{T}$ is a bijection onto $CSC(X, x_0)$. We define $\tau : CSC(X, x_0) \rightarrow SC(X, x_0)$ by:

$$\tau(\sigma(P, x)) = \begin{cases} (F(x) \cdot p_1(P); p_2(P)), & \text{for } x \in V_0 \\ (P, H(x, G(x))), & \text{for } x \in V_1 \setminus V_0 \\ (P, x), & \text{for } x \notin V_1 \end{cases}$$

for $P \in \mathcal{T}$ and $x \in X$. Since every element of $CSC(X, x_0)$ can be expressed as $\sigma(P, x)$ and $(F(x_0) \cdot p_1(P); p_2(P)) = (0; p_2(P))$, τ is well-defined. Points from copies of V_0 are mapped by τ into the square of $SC(X, x_0)$ and points from copies of $X \setminus V_1$ are mapped by τ into copies of X in $SC(X, x_0)$. Therefore, using only level-preserving homotopies we can show that $\tau \circ \sigma$ is homotopic to $\text{id}_{SC(X, x_0)}$ and that $\sigma \circ \tau$ is also homotopic to $\text{id}_{CSC(X, x_0)}$.

We use the same maps F, G and H , and also denote by σ the quotient map from $AC(X, x_0)$ to $CAC(X, x_0)$. When we use the presentation of

$CAC(X, x_0)$ via the cones

$$C(\widetilde{\bigvee}_{n \in \mathbb{N}}(X_{2n-1}, x_{2n-1})) \quad \text{and} \quad C(\widetilde{\bigvee}_{n \in \mathbb{N}}(X_{2n}, x_{2n})),$$

$V_{0,n}, V_{1,n}$ and U_n are copies of V_0, V_1 and U on X_n , respectively and we also use F, G and H for the copies.

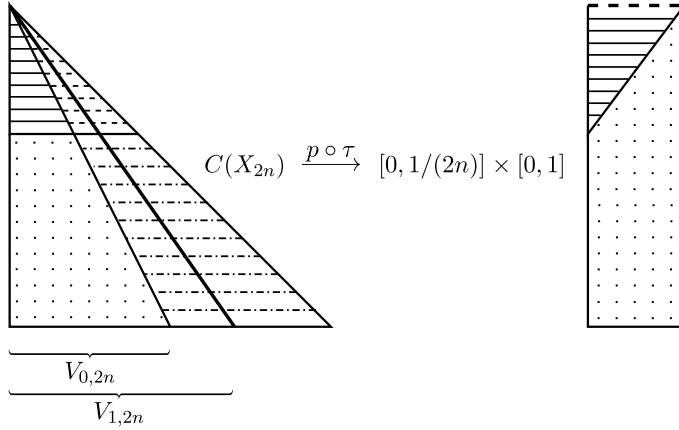

FIGURE 3. The figure visualizes the mapping τ . The hatching styles indicate to which regions the corresponding domains are mapped. Observe that only $p \circ \tau$ is pictured; in particular the τ -image of the dash-dotted area is considerably bigger than it is visible from the figure.

The homotopy equivalence between $AC(X, x_0)$ and $CAC(X, x_0)$ is proved similarly, but more care is necessary, because the homotopy inverse τ of σ , which we shall define in the sequel, is not level-preserving. We define τ only on $C(\widetilde{\bigvee}_{n \in \mathbb{N}}(X_{2n}, x_{2n}))$ for notational convenience, but the other case is similar. Let $\tau(x, s) =$

$$\begin{cases} ((1-s)F(x); s + (1-s)F(x)) & \text{for } (2n-1)/(2n) \leq s \leq 1, x \in X_{2n}, \\ (F(x)/(2n); s(1 + F(x)/(2n-1))) & \text{for } 0 \leq s < (2n-1)/(2n), x \in V_{0,2n}, \\ (H(x, G(x)), 2ns/(2n-1)) & \text{for } 0 \leq s < (2n-1)/(2n), \\ & x \in V_{1,2n} \setminus V_{0,2n}, \\ (x, 2ns/(2n-1)) & \text{otherwise.} \end{cases}$$

Figure 3 shows the restriction of $p \circ \tau$ to $C(X_{2n})$. We remark that $\sigma(0; t) = (x^*, t)$ and $\tau(x^*, t) = (0; t)$ and $(1 - 2n)/(2n)$ converge to 1. Using this information we can see that $\tau \circ \sigma$ is homotopic to $\text{id}_{AC(X, x_0)}$ and $\sigma \circ \tau$ is homotopic to $\text{id}_{CAC(X, x_0)}$. \square

PROOF OF THEOREM 1.2. By virtue of Theorem 1.1 the fact that $CSC(S^1)$ and $CAC(S^1)$ are homotopy equivalent implies the present theorem. To find this homotopy equivalence, we use embeddings of these spaces in \mathbb{R}^3 . We define subsets of these embeddings as follows:

$$S_n = \{(x, y, z) \mid (x - 1/n)^2 + y^2 = 1/n^2, z \in \mathbb{I}\},$$

$$T_n = \{(x, y, z) \mid \left(x - \left(\frac{1}{n+1} + \frac{z}{n(n+1)}\right)\right)^2 + y^2 = \left(\frac{1}{n+1} + \frac{z}{n(n+1)}\right)^2, z \in \mathbb{I}\},$$

$$U_n = \{(x, y, z) \mid (x - (1-z)/n)^2 + y^2 = (1-z)^2/n^2, z \in \mathbb{I}\},$$

$$V_n = \{(x, y, z) \mid (x + z/n)^2 + y^2 = z^2/n^2, z \in \mathbb{I}\},$$

$S_n^+ = S_n \cap (\mathbb{R} \times \{y \mid y \geq 0\} \times \mathbb{R})$ and $T_n^+ = T_n \cap (\mathbb{R} \times \{y \mid y \geq 0\} \times \mathbb{R})$.

By the preceding description, $CSC(S^1)$ is homotopy equivalent to the subspace $Y_0 = \bigcup_{n \in \mathbb{N}} (S_n \cup T_n)$ of \mathbb{R}^3 . Let Y_1 be the following subspace of \mathbb{R}^3 (see Figure 4):

$$[0, 2] \times \{0\} \times \mathbb{I} \cup \bigcup_{n \in \mathbb{N}} S_n^+ \cup T_n^+.$$

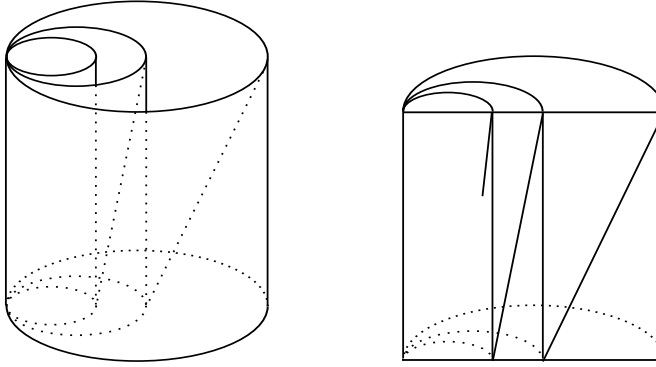

FIGURE 4. $CSC(S^1)$ and Y_1

The homotopy equivalence between the spaces $\bigcup_{n \in \mathbb{N}} \{(x, y) \mid (x - 1/n)^2 + y^2 = 1/n^2\}$ and $[0, 2] \times \{0\} \cup \bigcup_{n \in \mathbb{N}} \{(x, y) \mid (x - 1/n)^2 + y^2 = 1/n^2, y \geq 0\}$ induces a homotopy equivalence between Y_0 and Y_1 and it now suffices to establish the homotopy equivalence between Y_1 and $CAC(S^1)$. We use the presentation of $CAC(S^1)$ from the introduction of Section 3 and we realize it

in \mathbb{R}^3 as the following subspace:

$$\bigcup_{n \in \mathbb{N}} U_n \cup V_n.$$

Define $\sigma : Y_1 \rightarrow CAC(S^1)$ so that $\sigma(x, y, z) = (0, 0, z)$, if

$$\left(x - \frac{1}{n}\right)^2 + y^2 = \left(\frac{1}{n}\right)^2$$

or if

$$\left(x - \left(\frac{1}{n+1} + \frac{z}{n(n+1)}\right)\right)^2 + y^2 = \left(\frac{1}{n+1} + \frac{z}{n(n+1)}\right)^2$$

for $n \in \mathbb{N}$ and $z \in \mathbb{I}$, and so that σ maps level-preserving from

$$\left\{ (x; y) \mid 0 \leq y \leq \frac{x - 1/(n+1)}{n(n+1)}, \frac{1}{n+1} \leq x \leq \frac{1}{n} \right\}$$

onto U_n and from

$$\left\{ (x; y) \mid \frac{x - 1/(n+1)}{n(n+1)} \leq y \leq 1, \frac{1}{n+1} \leq x \leq \frac{1}{n} \right\}$$

onto V_n .

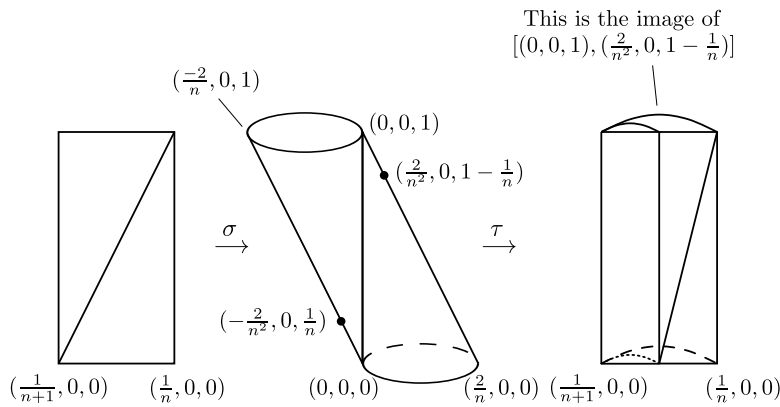

FIGURE 5. Partial illustrations of the maps σ and τ .

We define $\tau : Y_1 \rightarrow CAC(S^1)$ so that $\tau(0, 0, z) = (0, 0, z)$ for $z \in \mathbb{I}$ and so that τ maps U_n homeomorphically onto

$$S_n^+ \cup T_n^+ \cup \left\{ (x, y, z) \mid \frac{1}{n+1} \leq x \leq 1/n, y = 0, 0 \leq z \leq \frac{x - 1/(n+1)}{n(n+1)} \right\}$$

and V_n onto

$$S_{n+1}^+ \cup T_n^+ \cup \left\{ (x, y, z) \mid \frac{1}{n+1} \leq x \leq 1/n, y = 0, \frac{x - 1/(n+1)}{n(n+1)} \leq z \leq 1 \right\}.$$

We define τ uniformly with respect to n , in particular so that τ is $(1/n)$ -level-preserving on U_n and V_n .

In particular, τ maps the segment $[(0, 0, 1), (2/n^2, 1 - 1/n)]$ onto the arc

$$\{(x, y, 1) \mid (x - 1/n)^2 + y^2 = 1/n^2, y \geq 0\}$$

and the segment $[(0, 0, 0), (-2/n^2, 0, 1/n)]$ onto the arc

$$\{(x, y, 0) \mid (x - 1/(n+1))^2 + y^2 = 1/(n+1)^2, y \geq 0\}$$

which is the only dotted arc that we have drawn in Figure 5.

Since the segments $[(0, 0, 1), (2/n^2, 0, 1 - 1/n)]$ converge to $(0, 0, 1)$ and $[(0, 0, 0), (-2/n^2, 0, 1/n)]$ converge to $(0, 0, 0)$ when n tends to infinity and σ is level-preserving, and τ is $(1/n)$ -level-preserving on U_n and V_n , we can conclude that $\sigma \circ \tau$ and $\tau \circ \sigma$ are homotopic to the identity mapping on $CAC(S^1)$ and Y_1 , respectively. \square

4. PROOF OF THEOREM 1.3

The first lemma concerns a certain useful property of $AC(X, x)$ for any path-connected space X .

LEMMA 4.1. *Let X be a path-connected space. Then $p_2^{-1}([0, 1])$ and $p_2^{-1}((0, 1])$ are contractible in $AC(X, x)$. The same also holds for $CAC(X, x)$.*

PROOF. Since $p_2^{-1}(\{0\})$ is a strong deformation retract of $p_2^{-1}([0, 1])$, it suffices to show that $p_2^{-1}(\{0\})$ is contractible in $AC(X, x)$. Since $p_2^{-1}(\{0\})$ deforms to the segment $[(0; 1), (1; 1)]$, $p_2^{-1}(\{0\})$ is contractible in $AC(X, x)$. The contractibility of $p_2^{-1}((0, 1])$ in $AC(X, x)$ can be proved similarly. In the case of $CAC(X, x)$ the above procedure yields a point instead of the segment $[(0; 0), (1; 0)]$. \square

We prove (1),(2) and (3) separately.

4.1. Proof of Theorem 1.3: (1) and (2).

PROOF OF THEOREM 1.3 (1). The fact that $SC(\mathbb{H}, o)$ and $AC(\mathbb{H}, o)$ are not homotopy equivalent was proved in [7, Theorem 3.6], where it was established that any embedding of \mathbb{H} to $AC(\mathbb{H}, o)$ is null homotopic, while there exists an essential embedding of \mathbb{H} to $SC(\mathbb{H}, o)$.

Hence, for the second nonequivalence it suffices to show that any embedding of \mathbb{H} to $CSC(\mathbb{H}, o)$ is null homotopic. Let $f : \mathbb{H} \rightarrow CSC(\mathbb{H}, o)$ be an embedding. Let x^* be the identified points with copies of $o \in \mathbb{H}$. Since $CSC(\mathbb{H}, o)$ is locally contractible at points in $CSC(\mathbb{H}, o) \setminus \{x^*\} \times \mathbb{I}$, $f(o)$ belongs to $\{x^*\} \times \mathbb{I}$, which is the crucial difference between $CSC(\mathbb{H}, o)$

and $SC(\mathbb{H}, o)$. Therefore, except for finitely many circles of \mathbb{H} , f maps into $p_2^{-1}([0, 1])$ or $p_2^{-1}((0, 1])$. By a similar argument as in the proof of [3, Lemma 3.3] we can show that f is homotopic to a map f' into $p_2^{-1}([0, 1])$ or $p_2^{-1}((0, 1])$. By a similar argument as in the proof of [3, Theorem 1.1] we can then produce a null-homotopy of f' . \square

For a proof of Theorem 1.3(2) we need some notions and lemmas. For $AC(Z)$ and $P \in \bigcup_{n \in \mathbb{N}} \{1/(2n - 1)\} \times (0, 1] \cup \{1/(2n)\} \times [0, 1\}$, let $Z_P = p^{-1}(\{P\})$, which is homeomorphic to Z and $M_s = p_2^{-1}(\{s\})$ for $s \in \mathbb{I}$.

An interval $[a, b]$ with $0 \leq a < b \leq 1$ is called an *essential interval* for a flat continuous map $f : AC_n(Z) \rightarrow AC(Z)$, if the following hold:

- (1) f maps $p_2^{-1}(\{a\}) \cap AC_n(Z)$ into M_0 and $p_2^{-1}(\{b\})$ into M_1 ;
- (2) f maps $p_2^{-1}((a, b)) \cap AC_n(Z)$ into $p_2^{-1}((0, 1))$; and
- (3) for every $a < c < b$, $f|_{p_2^{-1}\{c\}}$ is homotopic to the restriction of the identity mapping on $AC_n(Z)$ to $p_2^{-1}\{c\}$ in $p_2^{-1}((0, 1))$.

For $s \in (0, 1)$ and $t \in \mathbb{I}$, we define a property $P(s, t)$ of H as follows:

$H(M_s \cap AC_n(Z), t) \subseteq p_2^{-1}((0, 1))$ and the restriction of $H(-, t)$ to $M_s \cap AC_n(Z)$ is homotopic to the identity mapping on $M_s \cap AC_n(Z)$ in $p_2^{-1}((0, 1))$.

We remark that by the flatness of H , if $H(M_s \cap AC_n(Z), t) \subseteq p_2^{-1}((0, 1))$, there is a neighborhood U of $(s; t)$ such that $H(M_{s'} \cap AC_n(Z), t') \subseteq p_2^{-1}((0, 1))$ for any $(s'; t') \in U$.

LEMMA 4.2. *Let Z be a compact path-connected space and $n \in \mathbb{N}$. Let $f : AC_n(Z) \rightarrow AC(Z)$ (or $f : AC_n(Z) \rightarrow CAC(Z)$) be a continuous map. If for each $y \in \mathbb{I}$ the set $p_2(f(M_y \cap AC_n(Z)))$ does not contain both points 0 and 1, f is homotopic to a flat map f_1 .*

Moreover, let $H : AC_n(Z) \times \mathbb{I} \rightarrow AC(Z)$ be a homotopy between the identity mapping on $AC_n(Z)$ and f such that for each $y \in \mathbb{I}$ and $t \in \mathbb{I}$, the set $p_2(H(M_y \cap AC_n(Z), t))$ does not contain both points 0 and 1. Then there exists a flat homotopy between the identity mapping and f_1 .

PROOF. Fix the number y . Let $A(y)$ and $B(y)$ be the minimum and the maximum of the function $p_2 \circ f : M_y \cap AC_n(Z) \rightarrow \mathbb{I}$, respectively, and also let

$$C(y) = \frac{A(y)}{1 + A(y) - B(y)}.$$

We remark that the continuity of $A(y)$ and $B(y)$ follows from the fact that the shape of $AC_n(Z)$ is like a direct product.

Let $\varphi(s_0, s_1, t) = s_0 + (s_1 - s_0)t$. For $x \in p_2^{-1}((0, 1))$ and $u \in \mathbb{I}$, let $x_u \in p_2^{-1}(\{u\})$ be the point determined by the retraction of $p_2^{-1}([p_2(x), u])$ or $p_2^{-1}([u, p_2(x)])$ to $p_2^{-1}(\{u\})$, which is derived from the direct product structure,

and for $x \in p_2^{-1}(\{0\} \cup \{1\})$ and $u \in \mathbb{I}$, let $x_u = x$. Define $F: AC_n \times \mathbb{I} \rightarrow AC_n$ by

$$F(x, t) = x_{\varphi(p_2(f(x)), C(p_2(f(x))), t)}.$$

Since $A(p_2(f(x)), t) = 0$ implies $C(p_2(f(x)), t) = 0$ and $B(p_2(f(x)), t) = 1$ implies $C(p_2(f(x))) = 1$ and both cannot occur at the same time, F is a deformation retraction, $F(-, 0)$ is f and $F(-, 1)$ is a flat map.

If f is a flat map, then $f_1 = f$. Since the identity mapping on AC_n is a flat map, applying this reasoning to the homotopy H we have a homotopy \overline{H} for the second statement, i.e., we define $A(y, t), B(y, t), C(y, t)$ using $H(x, t)$ instead of $f(x)$ and let

$$\overline{H}(x, t) = H(x, t)_{\varphi(p_2(H(x, t)), C(p_2(H(x, t))), t)}.$$

□

LEMMA 4.3. *Let Z be a noncontractible space and $H: AC_{2m-1, 2m}(Z) \times \mathbb{I} \rightarrow AC(Z)$ a flat homotopy. If $H(M_0 \cap AC_{2m-1, 2m}(Z), t_0) \subseteq p_2^{-1}((0, 1))$, then there exists a neighborhood U of $(0; t_0)$ such that H does not satisfy $P(s, t)$ for any $(s; t) \in U$ with $s > 0$. An analogous statement holds for $H(M_1 \cap AC_{2m-1, 2m}(Z), t_0) \subseteq p_2^{-1}((0, 1))$.*

PROOF. We have a neighborhood U of $(0; t_0)$ such that

$$H(M_s \cap AC_{2m-1, 2m}, t) \subseteq p_2^{-1}((0, 1))$$

for any $(s; t) \in U$. We fix $(s; t) \in U$ with $s > 0$. Let $P_n = (1/n; s)$ and $I_n = [P_{n+1}, P_n]$. Then we have $M_s = \{(0; s)\} \cup \bigcup_{n=1}^{\infty} I_n \cup Z_{P_n}$ and $M_s \cap AC_{2m-1, 2m}(Z) = Z_{P_{2m}} \cup Z_{P_{2m-1}} \cup I_{2m-1}$. Since $H(-, t)$ maps $\bigcup_{u \in [P_{2m-1}, A_{2m-1}]} Z_u$ into $p^{-1}(\mathbb{I} \times (0, 1))$, the restriction of $H(-, t)$ to $Z_{P_{2m-1}}$ is null-homotopic in $p^{-1}(\mathbb{I} \times (0, 1))$. Since M_s is a strong deformation retract of $p^{-1}(\mathbb{I} \times (0, 1))$ and $Z_{P_{2m-1}}$ is a retract of $p^{-1}(\mathbb{I} \times (0, 1))$ and $Z_{P_{2m-1}}$ is not contractible, the identity mapping on $Z_{P_{2m-1}}$ is not homotopic to the restriction of $H(-, t)$ to $Z_{P_{2m-1}}$, which implies that $P(s, t)$ does not hold.

To prove the statement for $H(M_1, t_0)$ we use $Z_{P_{2m}}$ and argue on a neighborhood of B_{2m} to obtain a similar conclusion. □

LEMMA 4.4. *Let $H: AC_n(\mathbb{H}, o) \times \mathbb{I} \rightarrow AC(\mathbb{H}, o)$ be a flat homotopy between the identity mapping on $AC_n(\mathbb{H}, o)$ and f . Then there exist $a_0, b_0 \in \mathbb{I}$ with $a_0 < b_0$ such that $[a_0, b_0]$ is an essential interval for f .*

PROOF. Let $d: [0, 1] \rightarrow S^1$ be a winding with the base point z_0 , i.e., both $d|[0, 1)$ and $d|(0, 1]$ are bijective continuous mappings with $d(0) = d(1) = z_0$.

We define a homotopy $H^*: S^1 \times \mathbb{I} \rightarrow S^1$ as follows:

$$H^*(u, t) = \begin{cases} d(p_2(H(M_{d^{-1}(u)}, t))) & \text{if } u \neq z_0 \text{ and } P(d^{-1}(u), t) \text{ holds;} \\ z_0, & \text{otherwise.} \end{cases}$$

First we show the continuity of H^* .

If $u \neq z_0$ and $P(d^{-1}(u), t)$ holds, the continuity at (u, t) is clear. Otherwise, $u \neq z_0$ and $P(d^{-1}(u), t)$ does not hold, or $u = z_0$. We consider two cases:

CASE 1. Suppose that $u \neq z_0$ and $P(d^{-1}(u), t)$ does not hold: If $p_2 \circ H(M_{d^{-1}(u)}, t) = \{0\}$ or $\{1\}$, then the continuity at (u, t) follows from that of H . Otherwise, since $H(-, t)$ maps $M_{d^{-1}(u)} \cap AC_n(Z)$ continuously with respect to u and t , the restriction of $H(-, t)$ to $M_{d^{-1}(u)} \cap AC_n(Z)$ is not homotopic to the identity mapping on $M_{d^{-1}(u)} \cap AC_n(Z)$ in $p^{-1}(\mathbb{I} \times (0, 1))$, i.e., H^* takes the value z_0 in a neighborhood of (u, t) .

CASE 2. Suppose that $u = z_0$: If each of $p_2(H(M_0 \cap AC_n(Z), t))$ and $p_2(H(M_1 \cap AC_n(Z), t))$ is equal to either $\{0\}$ or $\{1\}$, the continuity at (u, t) follows from that of H . The remaining case is when $p_2(H(M_0 \cap AC_n(Z), t)) \subseteq (0, 1)$ or $p_2(H(M_1 \cap AC_n(Z), t)) \subseteq (0, 1)$. In this case the continuity follows by Lemma 4.3.

We have shown that H^* is a homotopy and hence we have $a_0, b_0 \in \mathbb{I}$ with $a_0 < b_0$ such that $H^*(a_0, 1) = H^*(b_0, 1) = z_0$, $H^*(s, 1) \neq z_0$ for $a_0 < s < b_0$ and the orientation of the winding of $H^*(-, 1)$ on $[a_0, b_0]$ is the same as that of d . The last statement implies that $f(a_0) = H(a_0, 1) = 0$ and $f(b_0) = H(b_0, 1) = 1$. We have $P(s, 1)$ for $a_0 < s < b_0$, which implies that $[a_0, b_0]$ is an essential interval for f . \square

PROOF OF THEOREM 1.3 (2). To show the nonequivalence by contradiction suppose that we have $f : AC(\mathbb{H}, o) \rightarrow CAC(\mathbb{H}, o)$ and $g : CAC(\mathbb{H}, o) \rightarrow AC(\mathbb{H}, o)$ such that $g \circ f$ is homotopic to the identity mapping on $AC(\mathbb{H}, o)$ via a homotopy H .

There exists a sufficiently large n such that the restriction of H to $AC_n(\mathbb{H}, o) \times \mathbb{I}$ satisfies the condition for H in Lemma 4.2. Apply Lemma 4.2 to the homotopy H between the identity mapping on $AC_n(\mathbb{H}, o)$ and $g \circ f|_{AC_n(\mathbb{H}, o)}$, to get a flat homotopy \bar{H} between the identity mapping on $AC_n(\mathbb{H}, o)$ and a map which is given by applying Lemma 4.2 and homotopic to $g \circ f|_{AC_n(\mathbb{H}, o)}$. According to Lemma 4.4, we have an essential interval $[a_0, b_0]$ for $\bar{H}(-, 1)$. We remark that $g \circ f(p_2^{-1}((a_0, b_0)) \cap AC_n(\mathbb{H}, o)) \subseteq p_2^{-1}((0, 1))$.

First we claim that $f((1/m; s)) \in L$ for $a_0 \leq s \leq b_0$ and $m \geq n$. To show this by contradiction, suppose that $f((1/m; s_0)) \notin L$. Then $f((1/m; s_0))$ is contained in a local disk. This implies that the restriction of $\bar{H}(-, 1)$ to $p_2^{-1}(\{s_0\})$ is not homotopic to the identity on $p_2^{-1}(\{s_0\})$, since $\bar{H}(-, 1)$ is obtained from $g \circ f$ as in Lemma 4.2. Hence $f(\{1/m\} \times [a_0, b_0]) \subseteq L$ for $m \geq n$. Thus, for sufficiently large distinct m_0, m_1 , $f(\{1/m_0\} \times [a_0, b_0])$ and $f(\{1/m_1\} \times [a_0, b_0])$ are included as intervals on L . Therefore we conclude that some subinterval of $\{1/m_0\} \times [a_0, b_0]$ or $\{1/m_1\} \times [a_0, b_0]$ is mapped by $g \circ f$ outside of $\{1/m_0\} \times (0, 1)$ or outside of $\{1/m_1\} \times (0, 1)$, i.e., at least one of these intervals goes through the base square \mathbb{I}^2 by the homotopy \bar{H} . Hence

the restriction of $\overline{H}(-, 1)$ to $M_s \cap AC_n(Z)$ is not homotopic to the identity on $p_2^{-1}((0, 1))$ for $a_0 < s < b_0$, which is a contradiction. \square

4.2. *Proof of Theorem 1.3 (3).* Next we show that $CSC(\mathbb{H}, o)$ and $CAC(\mathbb{H}, o)$ are homotopy equivalent. Actually we show that $CSC(\mathbb{H}, o)$ is homotopy equivalent to $CSC(S^1, z_0)$ and $CAC(\mathbb{H}, o)$ is homeomorphic to $CAC(S^1, z_0)$. Then the conclusion follows from Theorems 1.1 and 1.2. To describe $CSC(\mathbb{H}, o)$ and $CAC(\mathbb{H}, o)$, we introduce the constructions $\mathbb{I}\widetilde{\bigvee}_{n \in \mathbb{N}} CSC(X_n, x_n)$ and $\mathbb{I}\widetilde{\bigvee}_{n \in \mathbb{N}} CAC(X_n, x_n)$.

For spaces X_n with $x_n \in X_n$, let $Y_n = CSC(X_n, x_n)$ and $Z_n = CAC(X_n, x_n)$. First we describe the construction of $\mathbb{I}\widetilde{\bigvee}_{n \in \mathbb{N}} CSC(X_n, x_n)$. We identify all copies of $(0; s)$ in Y_n for each $s \in \mathbb{I}$ and have the quotient set of the disjoint union of Y_n 's. Then we induce a topology so that any neighborhood of $\{(0; s) \mid s \in \mathbb{I}\}$ contains almost all Y_n 's. More precisely, let ${}_n p$ and ${}_n p_2$ be copies of the projections p and p_2 for Y_n , respectively. Then, a basic neighborhood base of $(0; y)$ is

$$\bigcup_{n=1}^k {}_n p^{-1}([0, \varepsilon) \times (a, b)) \cup \bigcup_{n=k}^{\infty} {}_n p_2^{-1}((a, b))$$

for $\varepsilon > 0$ and $a < y < b$. We denote this space by $\mathbb{I}\widetilde{\bigvee}_{n \in \mathbb{N}} CSC(X_n, x_n)$.

We define $\mathbb{I}\widetilde{\bigvee}_{n \in \mathbb{N}} CAC(X_n, x_n)$ analogously, i.e., we identify all copies of $(0; s)$ in Z_n for each $s \in \mathbb{I}$ and have the quotient set of the disjoint union of Z_n 's. Then we induce a topology so that any neighborhood of $\{(0; s) \mid s \in \mathbb{I}\}$ contains almost all Z_n 's.

It is then easy to see that $CSC(\widetilde{\bigvee}_{n \in \mathbb{N}}(X_n, x_n), x^*)$ is homeomorphic to $\mathbb{I}\widetilde{\bigvee}_{n \in \mathbb{N}} CSC(X_n, x_n)$ and $CAC(\widetilde{\bigvee}_{n \in \mathbb{N}}(X_n, x_n), x^*)$ is homeomorphic to $\mathbb{I}\widetilde{\bigvee}_{n \in \mathbb{N}} CAC(X_n, x_n)$, where x^* denotes the point that results from the identification of all x_n .

PROOF OF THEOREM 1.3 (3). We recall the proof of Theorem 1.2. There, the maps except τ assuring homotopy equivalences are level-preserving. Moreover τ can be taken to be ε -level-preserving for each $\varepsilon > 0$. Let X_n be copies of the circle S^1 . Accordingly, we have continuous maps $f_n : CSC(X_n) \rightarrow CAC(X_n)$, $g_n : CAC(X_n) \rightarrow CSC(X_n)$ and homotopies $F_n : CSC(X_n) \times \mathbb{I} \rightarrow CSC(X_n)$, $G_n : CAC(X_n) \times \mathbb{I} \rightarrow CAC(X_n)$ such that:

- (1) f_n is level-preserving;
- (2) g_n, F_n, G_n are $1/n$ -level-preserving; and
- (3) $F_n((0; y), t) = (0; y)$ and $G_n((0; y), t) = (0; y)$ for $y, t \in \mathbb{I}$.

Define $f : \mathbb{I}\widetilde{\bigvee}_{n \in \mathbb{N}} CSC(X_n) \rightarrow \mathbb{I}\widetilde{\bigvee}_{n \in \mathbb{N}} CAC(X_n)$, $g : \mathbb{I}\widetilde{\bigvee}_{n \in \mathbb{N}} CAC(X_n) \rightarrow \mathbb{I}\widetilde{\bigvee}_{n \in \mathbb{N}} CSC(X_n)$ and homotopies $F : \mathbb{I}\widetilde{\bigvee}_{n \in \mathbb{N}} CSC(X_n) \times \mathbb{I} \rightarrow \mathbb{I}\widetilde{\bigvee}_{n \in \mathbb{N}} CSC(X_n)$, $G : \mathbb{I}\widetilde{\bigvee}_{n \in \mathbb{N}} CAC(X_n) \times \mathbb{I} \rightarrow \mathbb{I}\widetilde{\bigvee}_{n \in \mathbb{N}} CAC(X_n)$ as unions of f_n, g_n, F_n, G_n

respectively. It suffices to verify their continuity. We show this for F , since the proofs for the others are similar. Continuity at points other than $(0; y)$ is obvious. For $\bigcup_{m=1}^{k_0} m p^{-1}([0, \varepsilon) \times (a, b)) \cup \bigcup_{m=k_0}^{\infty} m p_2^{-1}((a, b))$ with $\varepsilon > 0$ and $a < y_0 < b$, choose $k \geq k_0$ so that $a + 1/k < y_0 < b - 1/k$. Then, we have $a < p_2 \circ F_m((0; y), t) < b$ for $m \geq k$ and $t \in \mathbb{I}$. Hence using the continuity of F_m for $m < k$ we get the desired neighborhood of $(0; y_0)$ which assures the continuity of F at $(0; y_0)$. Since (\mathbb{H}, o) is $(\widetilde{\bigvee}_{n \in \mathbb{N}}(X_n, x_n), x^*)$, we conclude that $CSC(\mathbb{H}, o)$ and $CAC(\mathbb{H}, o)$ are homotopy equivalent. \square

5. PROOF OF THEOREM 1.4

We shall consider 2-cycles in $SC(T, x)$, where T is a 2-dimensional torus with a distinguished point x . For this purpose we prove some basic results about oriented closed surfaces and wedges of tori. Let (T_i, x_i) be copies of the torus (T, x) and $r_i : \bigvee_{i=1}^n (T_i, x_i) \rightarrow T_i$ be the retractions, where the attaching point of the wedge $\bigvee_{i=1}^n (T_i, x_i)$ is denoted by o and r_i maps T_j to o for $j \neq i$. We denote the genus of an oriented closed surface S by $g(S)$. Let z be a singular 2-cycle of a space X . We can write z as a formal sum $\sum_{i=0}^m \mu_i g_i$ where $\mu_i = \pm 1$ and g_i are continuous maps of the 2-simplex Δ_2 to X . For a 2-cycle z , $[z]$ denotes the homology class containing z .

Since z is a 2-cycle, by patching boundaries of copies of Δ_2 we get an oriented closed surface S_z and a continuous map $f_z : S_z \rightarrow X$. Let $[S_z]$ be the homology class of the fundamental cycle of S_z . Then we have $f_{z*}([S_z]) = [z]$. We refer the reader to [9, pp.108-109] for this standard construction.

In case S_z is not connected, we have 2-cycles z_1, \dots, z_k such that $\sum_{i=1}^k z_i = z$, each S_{z_i} is connected, and S_z is the disjoint union of S_{z_i} 's. An oriented closed surface S_z constructed from a 2-cycle z is generally not unique, but the following results hold for any construction of S_z .

LEMMA 5.1. *Let z be a singular 2-cycle of $\bigvee_{i=1}^n (T_i, x_i)$. Then the cardinality of $\{i \mid r_{i*}([z]) \neq 0\}$ is at most $g(S_z)$.*

PROOF. We prove this by induction on the genus $g(S_z)$. By the preceding remark we may suppose that S_z is connected. When $g(S_z) = 0$, S_z is a 2-sphere and so $r_i \circ f_z$ is null-homotopic for each i hence the conclusion is obvious. To prove the induction step by contradiction, suppose to the contrary. Without loss of generality we may assume that $g(S_z) \geq 1$ and $r_{i*}(z) \neq 0$ for $1 \leq i \leq g(S_z) + 1$. We may also assume that f_z is a piecewise linear map and $f_z^{-1}(\{o\})$ is a surface with boundary, by thickening if necessary.

We claim that we have a simple closed curve in $f_z^{-1}(\{o\})$ which is essential on S_z . To show this by contradiction, suppose that $f_z^{-1}(\{o\})$ does not contain any closed curve which is essential on S_z . Let C be a connected component of $f_z^{-1}(\{o\})$. We have at most finitely many disjoint connected boundaries of C which are simple closed curves. Since these are inessential, at least one

side of this simple closed curve on S_z is a disk. If this disk contains C for at least two simple closed curves in the boundary of C , S_z is a 2-sphere, which contradicts $g(S_z) \geq 1$. On the other hand, if this side does not contain C for every simple closed curve in the boundary of C , f_z is null-homotopic in this case, because $\pi_2(T_i)$ is trivial for each i and consequently $\pi_2(\bigvee_{i=1}^n T_i)$ is trivial. Hence, for exactly one simple closed curve in the boundary of C , the disk side of this simple closed curve contains C . Let D_C be this disk in S_z and define $f_C : S_z \rightarrow \bigvee_{i=1}^n (T_i, x_i)$ by $f_C(x) = o$ for $x \in D_C$ and $f_C(x) = f_z(x)$ for $x \notin D_C$. Then f_C is homotopic to f_z relative to $S_z \setminus D_C$. The simple closed curves of boundaries of D_{C_0} and D_{C_1} are disjoint for distinct components C_0 and C_1 of $f_z^{-1}(\{o\})$. Therefore, if D_{C_0} and D_{C_1} intersect, then $D_{C_0} \subseteq D_{C_1}$, $D_{C_1} \subseteq D_{C_0}$ or $D_{C_0} \cup D_{C_1} = S_z$. The last case implies that S_z is a 2-sphere, which contradicts $g(S_z) \geq 1$. Hence we have connected components C_j ($1 \leq j \leq m$) of $f^{-1}(\{o\})$ such that $D_{C_j} \cap D_{C_{j'}} = \emptyset$ for $j \neq j'$ and for each connected component E of $f_z^{-1}(\{o\})$ there exists C_j such that $D_E \subseteq D_{C_j}$. Now define $\bar{f} : S_z \rightarrow \bigvee_{i=1}^n (T_i, x_i)$ by $\bar{f}(x) = o$ for $x \in \bigcup_{j=1}^m D_{C_j}$ and $\bar{f}(x) = f_z(x)$ otherwise. Then \bar{f} is homotopic to f_z . Since D_{C_j} are pairwise disjoint disks, $S_z \setminus \bigcup_{j=1}^m D_{C_j}$ is connected, which implies that the range of \bar{f} is contained in some T_i . This contradicts the fact that $(r_i \circ f_z)_*$ is essential for $1 \leq i \leq k+1$ with $k \geq 1$. We have shown that there exists an essential closed curve L in $f_z^{-1}(\{o\})$ (we may suppose that this curve is piecewise linear).

We cut open S_z along L and paste two disks. We have a cycle z' such that z' is homologous to z and $f_{z'}$ extends f_z so that $f_{z'}$ takes the value o on these disks.

CASE 1: $S_{z'}$ is connected.

Since $g(S_{z'}) = g(S_z) - 1$, the cardinality of $\{i : r_{i*}(z') \neq 0\}$ is at most $g(S_z) - 1$. Since z is homologous to z' , we have a contradiction.

CASE 2: $S_{z'}$ has two connected components.

We have two cycles z_0 and z_1 such that $z_0 + z_1$ is homologous to z' , S_{z_0} and S_{z_1} are connected closed surfaces. Then we have $g(S_{z_0}) + g(S_{z_1}) = g(S_z)$. Since L is essential, $g(S_{z_0}), g(S_{z_1}) \geq 1$ and consequently $g(S_{z_0}), g(S_{z_1}) < g(S_z)$. Now there exists i_0 such that the both $r_{i_0*}([z_0]) = 0$ and $r_{i_0*}([z_1]) = 0$, which contradicts $r_{i_0*}([z_0]) + r_{i_0*}([z_1]) = r_{i_0*}([z]) \neq 0$. \square

COROLLARY 5.2. *Let z be a singular 2-cycle of $\tilde{\bigvee}_{i \in \mathbb{N}} (T_i, x_i)$. Then the cardinality of $\{i \mid r_{i*}([z]) \neq 0\}$ is at most $g(S_z)$.*

PROOF. To show this by contradiction, suppose that the cardinality of $\{i \mid r_{i*}([z]) \neq 0\}$ is greater than $g(S_z)$. We have $F \subseteq \mathbb{N}$ such that the cardinality of F is greater than $g(S_z)$ and $r_{i*}([z]) \neq 0$ for every $i \in F$. Let $r_F : \tilde{\bigvee}_{i \in \mathbb{N}} (T_i, x_i) \rightarrow \bigvee_{i \in F} (T_i, x_i)$ be the retraction projecting every torus T_j with $j \notin F$ to o . We remark that we can construct $S_{r_{F\#}(z)}$ for $r_{F\#}(z)$

with $S_{r_{F\#}(z)} = S_z$. Since $r_{i_*}([r_{F\#}(z)]) = r_{i_*}([z])$ for $i \in F$, the cardinality $\{i \in F : r_{i_*}([r_{F\#}(z)]) \neq 0\}$ is greater than $g(S_{r_{F\#}(z)})$ which contradicts Lemma 5.1. \square

PROOF OF THEOREM 1.4. First we recall the following Mayer-Vietoris sequence for $SC(T)$:

$$H_2(p_2^{-1}((0, 1))) \xrightarrow{i_{0*} - i_{1*}} H_2(p_2^{-1}([0, 1])) \oplus H_2(p_2^{-1}((0, 1])) \xrightarrow{j_{0*} + j_{1*}} H_2(SC(T)),$$

where $i_0 : p_2^{-1}((0, 1)) \rightarrow p_2^{-1}([0, 1])$, $i_1 : p_2^{-1}((0, 1)) \rightarrow p_2^{-1}((0, 1])$, $j_0 : p_2^{-1}([0, 1]) \rightarrow SC(T)$ and $j_1 : p_2^{-1}((0, 1]) \rightarrow SC(T)$ are the inclusions. We have deformation retractions $r_0 : p_2^{-1}([0, 1]) \rightarrow M_0$, $r_1 : p_2^{-1}((0, 1]) \rightarrow M_1$ and $r_{1/2} : p_2^{-1}((0, 1)) \rightarrow M_{1/2}$. We observe that M_0, M_1 and $M_{1/2}$ are homotopy equivalent to the Hawaiian tori wedge, more precisely, by the local contractibility of tori we have the homotopy equivalences

$$\begin{aligned} M_0 &\simeq \widetilde{\bigvee}_{n \in \mathbb{N}} p^{-1}(\{A_n\}), \\ M_1 &\simeq \widetilde{\bigvee}_{n \in \mathbb{N}} p^{-1}(\{B_n\}), \\ M_{1/2} &\simeq \widetilde{\bigvee}_{n \in \mathbb{N}} p^{-1}(\{C_n\}). \end{aligned}$$

Let $c_{A_k} : M_0 \rightarrow p^{-1}(\{A_k\})$ be the retraction so that $c_{A_k}(M_0 \setminus p^{-1}(\{A_k\})) = \{A_k\}$ and let $c_{B_k} : M_1 \rightarrow p^{-1}(\{B_k\})$ and $c_{C_k} : M_{1/2} \rightarrow p^{-1}(\{C_k\})$ be similar retractions (see Figure 1). Finally, let $r_{A_k} = c_{A_k} \circ r_0$, $r_{B_k} = c_{B_k} \circ r_1$ and $r_{C_k} = c_{C_k} \circ r_{1/2}$.

Since $p^{-1}(\{C_1\})$ is homeomorphic to T , we let z be the standard cycle such that $[z]$ is the generator of $H_2(p^{-1}(\{C_1\}))$. We'll show that $[z]$ is nontrivial as an element of $H_2(SC(T))$. To show this by contradiction we suppose that $[z] = 0$ in $H_2(SC(T))$. Since z is a cycle in $p_2^{-1}([0, 1])$, we have $[z]_0 \in H_2(p_2^{-1}([0, 1]))$, where $[*]_0$ denotes a homology class in $H_2(p_2^{-1}([0, 1]))$. Since $j_{0*}([z]_0) + j_{1*}(0) = [z] = 0$, we have $u \in H_2(p_2^{-1}((0, 1)))$ such that $i_{0*}(u) = [z]_0$ and $-i_{1*}(u) = 0$.

Then we have $r_{A_1*} \circ i_{0*}(u) = r_{A_1*}([z]_0) = 1$ and $r_{A_k*} \circ i_{0*}(u) = r_{A_k*}([z]_0) = 0$ for $k \geq 2$ and $r_{B_k*} \circ i_{1*}(u) = -r_{B_k*}(0) = 0$ for $k \in \mathbb{N}$. Consider the above homotopy equivalences of M_0 and $M_{1/2}$ together with the deformation retractions r_0 and $r_{1/2}$. Then we can see that $H_2(p^{-1}(\{C_{2k-2}\})) \oplus H_2(p^{-1}(\{C_{2k-1}\}))$ is a summand of $H_2(p^{-1}((0, 1)))$ and $H_2(p^{-1}(\{A_k\}))$ is a summand of $H_2(p^{-1}([0, 1]))$. Therefore we can see that $i_{0*}|_{H_2(p^{-1}(\{C_{2k-2}\}))}$ and $i_{0*}|_{H_2(p^{-1}(\{C_{2k-1}\}))}$ are isomorphisms onto $H_2(p^{-1}(\{A_k\}))$ for $k \geq 2$ and similarly $i_{1*}|_{H_2(p^{-1}(\{C_{2k-1}\}))}$ and $i_{1*}|_{H_2(p^{-1}(\{C_{2k}\}))}$ are isomorphisms onto $H_2(p^{-1}(\{B_k\}))$ for $k \in \mathbb{N}$ and hence we have $r_{C_1*}(u) = 1$ and $r_{C_2*}(u) = -1$ and successively $r_{C_{2k+1}*}(u) = 1$ and $r_{C_{2k+2}*}(u) = -1$ for $k \in \mathbb{N}$. Since $u \in H_2(p_2^{-1}((0, 1)))$, we have

a singular 2-cycle z_0 of $p_2^{-1}((0,1))$ with $[z_0] = u$, where $p_2^{-1}((0,1))$ is homotopy equivalent to $\tilde{\bigvee}_{i \in \mathbb{N}}(T_i, x_i)$. According to the description preceding Lemma 5.1 we have a closed surface S_{z_0} . By Corollary 5.2 the cardinality of $\{i \mid r_{C_{i*}}(u) \neq 0\}$ is at most $g(S_{z_0})$, which is a contradiction.

Next we consider the following property of a space:

There exists a point x such that any neighborhood of x contains an image of a nontrivial 2-cycle.

This property is homotopy invariant.

Since $p_2^{-1}([0,1])$ and $p_2^{-1}((0,1))$ are contractible by Lemma 4.1, $CAC(T)$ does not have this property. But for $CSC(T)$ any neighborhood of a point $(0; y)$ contains an image of a 2-cycle which is homologous to the standard 2-cycle z , which is nontrivial. We have thus shown that $CSC(T)$ and $CAC(T)$ are not homotopy equivalent. \square

REMARK 5.3. For the proof of Theorem 1.4 a weaker assertion than Lemma 5.1 is sufficient. What is actually necessary is a bound on the cardinality of $\{i \mid r_{i*}([z]) \neq 0\}$ and this bound can be obtained by a surgery, i.e., by cutting open some $f^{-1}(T_i)$ instead of $f^{-1}(\{o\})$ in the proof of Lemma 5.1, which is easier. Since Lemma 5.1 itself is a basic fact, we have stated this exact form.

6. PROOF OF THEOREM 1.6

PROOF OF THEOREM 1.6. The statement (1) of Theorem 1.6 is a corollary of [2, Theorem A.1] and so we explain the notions and results around it. The free σ -product of groups, which is a subgroup of the inverse limit of finite free products of groups ([10]), is defined by using countably infinite words as a generalization of the usual free products ([2, Definition 1.2]). We refer the reader to [2, Definition 1.2] for a precise definition. Then for locally strongly contractible spaces X_n , $\pi_1(\tilde{\bigvee}_{n \in \mathbb{N}}(X_n, x_n))$ is isomorphic to the free σ -product of $\pi_1(X_n, x_n)$ by [2, Theorem A.1]. Thus we have shown (1).

Next we show (2). Let o be the distinguished point of the Hawaiian tori wedge \mathbb{H}_T and T_n be the n -th factor of \mathbb{H}_T . Let $f : \mathbb{I}^2 \rightarrow \mathbb{H}_T$ be a continuous map such that $f(\partial\mathbb{I}^2) = \{o\}$. We have the countable family \mathcal{U} consisting of pairwise disjoint connected open sets such that $\mathbb{I}^2 \setminus f^{-1}(\{o\}) = \bigcup \mathcal{U}$. For each $U \in \mathcal{U}$, $f(U)$ is contained in some T_n . Since each torus T_n is locally strongly contractible at o and a neighborhood of o contains almost all T_n , we may assume that $\{U \in \mathcal{U} : f(U) \subseteq T_n\}$ is finite for each T_n and also that each $U \in \mathcal{U}$ is an open polygon. We remark that U may have holes and it divides \mathbb{I}^2 into finitely many, possibly only one, connected components. For each $U \in \mathcal{U}$, let D_U be the open disk such that $\mathbb{I}^2 \setminus D_U$ is the unique connected component of $\mathbb{I}^2 \setminus U$ containing $\partial\mathbb{I}^2$. Then we have $U \subseteq D_U$. For $U, V \in \mathcal{U}$, we define $U \prec V$, if U is contained in D_V but V is not contained in D_U .

Since \prec is a partial order and \mathcal{U} is at most countable, we have an order-preserving map $\rho : \mathcal{U} \rightarrow \mathbb{Q}$. The complement of the Cantor ternary set consists of a disjoint union of open intervals and the disjoint intervals are ordered naturally and this ordering is isomorphic to that of the rationals \mathbb{Q} . We number the open intervals as (a_q, b_q) by $q \in \mathbb{Q}$ so that $p < q$ implies $b_p < a_q$. For $U \in \mathcal{U}$ we define $f_U : \overline{D_U} \rightarrow \mathbb{H}_T$ such that $f_U(x) = f(x)$ for $x \in U$ and $f_U(x) = o$ for $x \in \overline{D_U} \setminus U$.

We define a homotopy $H : \mathbb{I}^2 \times \mathbb{I}$ so that $H(x, 0) = f(x)$ for $x \in \mathbb{I}^2$, $H(x, t) = o$ for $x \in \partial\mathbb{I}^2, t \in \mathbb{I}$ and $H(x, 1) = o$ for $x \in \mathbb{I}^2$. For this purpose we define H first on some parts.

For each $U \in \mathcal{U}$, we define $H(x, t) = f(x)$ for $x \in U$ and $t \leq a_{\rho(U)}$ and let $H|_{\overline{D_U} \times [a_{\rho(U)}, b_{\rho(U)}]}$ to be a homotopy from f_U to the constant map to $\{o\}$. Now, H is continuous on $\overline{D_U} \times [a_{\rho(U)}, b_{\rho(U)}] \cup \overline{U} \times [0, a_{\rho(U)}}$ for each $U \in \mathcal{U}$.

According to the definitions of ρ and D_U the defined parts are overlapping only where the value of H is o . To see this, suppose that $D(U) \cap D(V) \neq \emptyset$ for distinct U and V . Then we have $D(U) \cap V \neq \emptyset$ or $D(V) \cap U \neq \emptyset$. Since U and V are disjoint and each of them is connected, we have $V \subseteq D(U)$ or $U \subseteq D(V)$ and hence $V \prec U$ or $U \prec V$. We only deal with the case $V \prec U$. Since $U \cap V = \emptyset$ and $b_{\rho(V)} < a_{\rho(U)}$, we have

$$(D_U \times [a_{\rho(U)}, b_{\rho(U)}] \cup U \times [0, a_{\rho(U)}]) \cap (D_V \times [a_{\rho(V)}, b_{\rho(V)}] \cup V \times [0, a_{\rho(V)}]) = \emptyset$$

and we conclude that the defined parts are overlapping only where the value of H is o .

We define $H(x, t) = o$ for the remaining undefined parts. We need to show the continuity of H . A crucial matter is the accumulation of $H^{-1}(T_n)$ for infinitely many n , but we define the value of H to be o for such a point. Since each neighborhood of o contains almost all T_n and $\{U \in \mathcal{U} : f(U) \subseteq T_n\}$ is finite for each T_n , the continuity of H is now clear. Since $H(x, 1)$ is defined as the remaining undefined parts, H is a homotopy to the constant map to $\{o\}$, which implies that f is null-homotopic.

In the remaining part we shall prove (3). Let f be a continuous map from a closed surface S_z to \mathbb{H}_T . Let r_i be the retraction of \mathbb{H}_T to the i -th factor. By Corollary 5.2 $r_i \circ f$ is null-homologous for almost all i . As in the proof of (2) we may suppose that each connected component of $f^{-1}(\mathbb{H}_T \setminus \{o\})$ is an open subsurface. Next we find a simple closed curve in $f^{-1}(\{o\})$ which is essential in the surface. We cut open along the simple closed curve. We now iterate this procedure.

Hence we have g_0, \dots, g_n such that

- (a) the domain S_{z_i} of each g_i is a connected closed surface;
 - (b) the singular cycle $z_1 + \dots + z_n$ is homologous to z ;
 - (c) every simple closed curve in $g_i^{-1}(\{o\})$ is null-homotopic in the surface;
- and

(d) each connected component of $g_i^{-1}(\mathbb{H}_T \setminus \{o\})$ is an open subsurface.

We fix g_i . Let U be a connected component of $g_i^{-1}(\mathbb{H}_T \setminus \{o\})$. Then by the property (c) every simple closed curve in the boundary of U bounds a disk. Since the genus of S_z is positive, at most one of those closed disks contains U . If there is no such disk, the complement of U of the surface is covered by those finitely many disks. Then by Theorem 1.6(2) the restriction of g_i to each disk is homotopic to the constant o and hence we conclude that g_i is homotopic to a map into a single T_j for $j \in \mathbb{N}$. Otherwise, for each $U \in \mathcal{U}$ there exists an open disk D_U which contains U and whose boundary is a connected component of the boundary of U . Now we define $U \prec V$ if $U \subseteq D_V$, but $V \not\subseteq D_U$ in a similar way as in the proof of (2).

If D_U contains V and D_V contains U , then we have $U = V$. To see this by contradiction, suppose that $U \neq V$. Then, since $U \cap V = \emptyset$ and ∂D_V is a connected component of ∂V , we have $S_{z_i} \setminus D_U \subseteq D_V$ and this implies that S_{z_i} is a sphere, which is a contradiction. Hence $U \prec V$ is a partial order as in the proof of (2). In addition, since S_{z_i} is a surface, for distinct U and V , $D(U) \cap D(V) \neq \emptyset$ implies $D(U) \cap V \neq \emptyset$ or $D(V) \cap U \neq \emptyset$ as in (2) and consequently $V \prec U$ or $U \prec V$. Now we continue as in the proof of (2). The difference is that the domain is a closed surface S_{z_i} instead of a square, but the proof is formally the same and we have a homotopy from g_i to the constant map to $\{o\}$. Now all of the above implies that $[z] \in \bigoplus_{i \in \mathbb{N}} H_2(T_i) \cong \bigoplus_{\mathbb{N}} \mathbb{Z}$. Since $\bigoplus_{i \in \mathbb{N}} H_2(T_i) \leq H_2(\mathbb{H}_T)$, we have

$$H_2(\mathbb{H}_T) = \bigoplus_{i \in \mathbb{N}} H_2(T_i) \cong \bigoplus_{\mathbb{N}} \mathbb{Z}.$$

□

We complete this paper with the following three interesting problems which remain open:

PROBLEM 6.1. *Is the group $H_3(\mathbb{H}_T)$ trivial?*

PROBLEM 6.2. *Does there exist a 2-dimensional Peano continuum which is cell-like, simply connected, noncontractible, and aspherical in dimension 2?*

PROBLEM 6.3. *Does there exist a finite-dimensional noncontractible Peano continuum whose homotopy groups are trivial?*

ACKNOWLEDGEMENTS.

This research was supported by the Slovenian Research Agency grants P1-0292-0101-04, J1-4144-0101-07, J1-2057-0101 and the Polish-Slovenian grant BI-P1-2010-2011-001. The first author was partially supported by the Grant-in-Aid for Scientific research (C) of Japan No. 20540097 and 23540110.

REFERENCES

- [1] G. Conner, M. Meilstrup, D. Repovš, A. Zastrow and M. Željko, *On small homotopies of loops*, *Topology Appl.* **155** (2008), 1089–1097.

- [2] K. Eda, *Free σ -products and non-commutatively slender groups*, J. Algebra **148** (1992), 243–263.
- [3] K. Eda, U. H. Karimov and D. Repovš, *A construction of noncontractible simply connected cell-like two-dimensional Peano continua*, Fundamenta Math. **195** (2007), 193–203.
- [4] K. Eda, U. H. Karimov and D. Repovš, *A nonaspherical cell-like 2-dimensional simply connected continuum and related constructions*, Topology Appl. **156** (2009), 515–521.
- [5] K. Eda, U. Karimov and D. Repovš, *The second homotopy group of $SC(Z)$* , Glas. Mat. Ser. III **44(64)** (2009), 493–498.
- [6] K. Eda, U. Karimov and D. Repovš, *On the singular homology of one class of simply-connected cell-like spaces*, Mediterr. J. Math. **8** (2011), 153–160.
- [7] K. Eda, U. H. Karimov and D. Repovš, *On 2-dimensional nonaspherical cell-like Peano continua. A simple approach*, Mediterranean J. Math. **10** (2013), 519–528.
- [8] K. Eda and K. Kawamura, *Homotopy and homology groups of the n -dimensional Hawaiian earring*, Fund. Math. **165** (2000), 17–28.
- [9] A. Hatcher, Algebraic Topology, Cambridge Univ. Press, Cambridge, 2002.
- [10] G. Higman, *Unrestricted free products and varieties of topological groups*, J. London Math. Soc. **27** (1952), 73–81.
- [11] E. H. Spanier, Algebraic Topology, McGraw-Hill, New York-Toronto, 1966.

K. Eda
 School of Science and Engineering
 Waseda University
 Tokyo 169-8555
 Japan
E-mail: eda@logic.info.waseda.ac.jp

U.H. Karimov
 Institute of Mathematics
 Academy of Sciences of Tajikistan
 Ul. Ainy 299^A, Dushanbe 734063
 Tajikistan
E-mail: umedkarimov@gmail.com

D. Repovš
 Faculty of Education, and Faculty of Mathematics and Physics
 University of Ljubljana
 P.O.Box 2964, Ljubljana 1001
 Slovenia
E-mail: dusan.repovs@guest.arnes.si

A. Zastrow
 Institute of Mathematics
 Gdansk University
 ul. Wita Stwosza 57, 80-952 Gdańsk
 Poland
E-mail: zastrow@mat.ug.edu.pl

Received: 29.10.2011.
Revised: 17.8.2012.